

Hydraulic Clamp Nut

Piston system



Series 010 / 110

Features of series with - DA

Pressure indicator
Axial operating
with Allen key
Medium remains into the system



The actuator screws has to be turned into the body by using the enclosed Allen key.
 The internal medium will flow into the circular groove and raise the ring piston.
 With less manual force you create a big hydraulic clamping force.
 For to relieve the clamp nut put the actuator screws to the start position
 and move the nut to the opposite direction.
 The medium remains into the system.

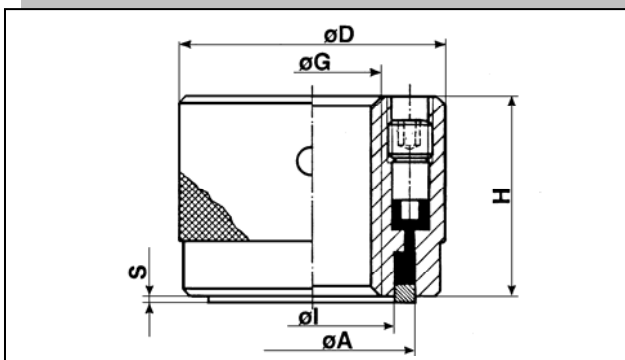

Clamping range 2 mm

Thread	Ring piston		Outer Diameter	Height	Clamping force (achieved by hand)	Part No
$\text{ØG}_{\text{max.}}$	ØA	ØI	ØD	H	in kN	Clamping range S 2 mm
52	72	60	90	60	110	010.02.052-DA
68	92	82	110	60	120	010.02.068-DA
80	100	88	120	70	160	010.02.080-DA
100	125	110	145	80	190	010.02.100-DA

Against corrosion our hydraulic clamp nuts are protected with a brown finish.
 The standard sealing systems are suitable for temperatures up to 80°.
 The ring piston is locked against drop out.

Special design of hydraulic clamp nuts on request



AVEMAR CZECH s.r.o. | speciální armatury pro měření a regulaci
 Branch office | Lihovarská 1199/10 | 716 03 Ostrava - Radvanice | česká republika
 Tel.: +420 596 232 996 (7) | Fax: +420 596 232 998 | www.avemar.cz | avemar@avemar.cz

Pressure Indicator

NORIS

Series 010 / 110

Detailed Description

Picture shows pressure indicator retracted.

System pressure within the clamp nut is less respectively similar to the pre-tension of spring washer into the clamp nut.



Picture shows pressure indicator visible up to 1. mark.

System pressure within the clamp nut is 1/2 of reachable system pressure and is equivalent 1/2 of clamp force.



Picture shows pressure indicator visible up to 2. mark.

Maximum system pressure within the clamp nut is achieved and maximum clamp force at extended ring piston is achieved.



Pressure indicator is designed for easy presentation of existing system pressure within clamp nut. On the basis of the marks at pressure indicator clamp force can be derived from.

Each type of clamp nut (Clamp nuts with actuator screws, clamp nuts with grease nipple, clamp nuts with oil nipple) can be equipped with pressure indicator as far as sufficient space existing. Marks at pressure indicator can be custom- tailored designed.

Pressure indicator works with a spring column of alternating single spring washers, whose characteristic curve proceed degressive.

(1/2 of system pressure \neq 1/2 traverse path.)

Each clamp nuts equipped with pressure indicator have a label wich clamp force is achieved at 1. and 2. mark.

NORIS

ARMATUREN BURKENSTEIN GMBH & CO. KG
– ABTEILUNG SPANNELEMENTE –

D-90411 Nürnberg
Neumeyerstr.13

Telefon: + 49 (0) 911/ 52 15 06 3
Telefax: + 49 (0) 911/ 52 24 40

E-Mail: noris@noris-armaturen.de
Internet: www.noris-armaturen.de